

**NABCO:
A TRUSTED
PARTNER**

Security personnel in the U.S. and more than 20 countries around the world rely on NABCO.

Our long-term partnerships have enabled NABCO customers to improve safety and up-level readiness against constantly evolving threats.

OUR CUSTOMERS:

- The FBI, ATF, CIA, NSA, NIH, Secret Service and Capitol Police
- More than 125 state & local bomb and HAZMAT squads in the United States
- Security planners for Presidential Inaugurals and other high profile events
- More than 30 U.S. airports
- The U.S. Army, Navy, Marine Corps and Air Force



Since 1986, NABCO has been a leading manufacturer of security solutions for public safety, security and defense organizations in the U.S. and worldwide. NABCO is a small business and proud U.S. manufacturer based in Baltimore, Maryland.

NABCO solutions are highly sought after by security planners for the world's most high-profile events-including Super Bowls and Presidential Inaugurals. NABCO expertly provides solutions for airports, police departments, transportation hubs and Defense personnel.

Many organizations have partnered with NABCO for decades for ongoing design, training, assessments and upgrades, and NABCO's products continue to be integrated into training & certification programs across the United States.



Follow the QR code on each page for more information!



10001 Franklin Square Drive • Nottingham MD USA 21236
410-933-0401 • FAX: 410-360-3255
Website: www.nabcosystems.com
Email: info@nabcosystems.com

**NABCO:
A TRUSTED
PARTNER**

Security personnel in the U.S. and more than 20 countries around the world rely on NABCO.

Our long-term partnerships have enabled NABCO customers to improve safety and up-level readiness against constantly evolving threats.

OUR CUSTOMERS:

- The FBI, ATF, CIA, NSA, NIH, Secret Service and Capitol Police
- More than 125 state & local bomb and HAZMAT squads in the United States
- Security planners for Presidential Inaugurals and other high profile events
- More than 30 U.S. airports
- The U.S. Army, Navy, Marine Corps and Air Force



PUBLIC SAFETY PRODUCTS

METIS Sliding Bollard System 3

High Security Bollards 4

- 4 Automatic Retractable Bollards*
- 5 Semi-Automatic Retractable Bollards*
- 6 Fixed Bollards*
- 7 Shallow Mount Fixed and Removable Bollards*

Surface Mounted Vehicle Damper 8

Active Vehicle Barriers 9

- 10 Optimus A-260*

Arm Barriers 11

- 11 High Security Arm Barriers*

Additional Products 12

Command and Control 12

- 12 Off-Site Security Operation*

Suspected Device Containment 13

- 13 Suspected Parcel Containment Vessel (SPCV)*
- 14 Suspected Luggage Containment Vessels (SLCV)*
- 15 SLCV/SPCV Spec Sheet*

Blast Resistant Trash Receptacles 16

Explosive Detection 17

- 17 EXPRAY® and DROPEX*

Contact Us 18

**NABCO:
A TRUSTED
PARTNER**

Security personnel in the U.S. and more than 20 countries around the world rely on NABCO.

Our long-term partnerships have enabled NABCO customers to improve safety and up-level readiness against constantly evolving threats.

OUR CUSTOMERS:

- The FBI, ATF, CIA, NSA, NIH, Secret Service and Capitol Police
- More than 125 state & local bomb and HAZMAT squads in the United States
- Security planners for Presidential Inaugurals and other high profile events
- More than 30 U.S. airports
- The U.S. Army, Navy, Marine Corps and Air Force

METIS Sliding Bollard System

The METIS is an innovative all electric sliding bollard system. Chain driven and designed to be “plug-and-play” for ease of use, the METIS combines crash performance with a 21st century design.

**Follow the QR code
for a video of the
METIS in operation,
and contact NABCO
for more information!**



10001 Franklin Square Drive • Nottingham MD USA 21236
410-933-0401 • FAX: 410-360-3255
Website: www.nabcosystems.com
Email: info@nabcosystems.com



**NABCO:
A TRUSTED
PARTNER**

Security personnel in the U.S. and more than 20 countries around the world rely on NABCO.

Our long-term partnerships have enabled NABCO customers to improve safety and up-level readiness against constantly evolving threats.

OUR CUSTOMERS:

- The FBI, ATF, CIA, NSA, NIH, Secret Service and Capitol Police
- More than 125 state & local bomb and HAZMAT squads in the United States
- Security planners for Presidential Inaugurals and other high profile events
- More than 30 U.S. airports
- The U.S. Army, Navy, Marine Corps and Air Force



High Security Bollards

Through our partnership with EL-GO Team Security Systems we are able to deliver innovative and visually appealing crash-rated perimeter protection systems that match curb-appeal with top rated performance.

The bollard systems may be operated wirelessly from an off-site location integrated to all other security components. All bollards come crash-certified and have ratings and sizes to suit any customer requirement.



Automatic Retractable Bollards

The high security, retractable bollard systems have been successfully tested and certified to the highest standards of K12 and PAS68 by authorized crash test facilities. The retractable bollards are available to be driven electrically or pneumatically upon request and may be equipped with LED lighting.

The ELGO-Team bollards are offered in a wide selection of categories:

- Retractable
- Shallow-mount
- Semi-Automatic
- Fixed
- Removable
- Fold down
- T-Bollards



	BLG-02-EH	BLG-04-EH	BLG-05-K12
Rating	K4	K8	K12/PAS68
Height Above Road	27.5"	29.5"	35" or 39"
Diameter	9"	11"	11"
Resistance	13600lbs/30mph	13600lbs/40mph	15000lbs/53mph

**NABCO:
A TRUSTED
PARTNER**

Security personnel in the U.S. and more than 20 countries around the world rely on NABCO.

Our long-term partnerships have enabled NABCO customers to improve safety and up-level readiness against constantly evolving threats.

OUR CUSTOMERS:

- The FBI, ATF, CIA, NSA, NIH, Secret Service and Capitol Police
- More than 125 state & local bomb and HAZMAT squads in the United States
- Security planners for Presidential Inaugurals and other high profile events
- More than 30 U.S. airports
- The U.S. Army, Navy, Marine Corps and Air Force



Semi-Automatic Retractable Bollards

The BLG-02, BLG-04 and BLG05 models can be supplied semi-automatic without any alteration of crash performance or visual appearance. The semi-automatic bollards are ideal for security planners working in power denied environments. The BLG-02 is supplied with a gas piston to assist the operator raising and lowering the bollard tube. This allows for the functionality and ease of a fully automatic bollard, but is applicable to installation locations where electrical hook-ups are not an option. The BLG-04 and BLG-05 models are supplied with a manual pump to pressurize and de-pressurize the piston within the bollard housing allowing the smooth extension and retraction of the bollard.

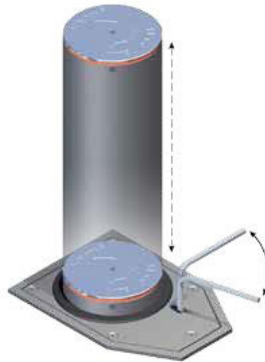

- Gas piston assisted
- No electrical hook-up required
- Cost effective
- Zero on-site integration
- K4, K8, K12 crash ratings
- Optional LED lighting package



10001 Franklin Square Drive • Nottingham MD USA 21236
410-933-0401 • FAX: 410-360-3255
Website: www.nabcosystems.com
Email: info@nabcosystems.com

**NABCO:
A TRUSTED
PARTNER**

Security personnel in the U.S. and more than 20 countries around the world rely on NABCO.

Our long-term partnerships have enabled NABCO customers to improve safety and up-level readiness against constantly evolving threats.

OUR CUSTOMERS:

- The FBI, ATF, CIA, NSA, NIH, Secret Service and Capitol Police
- More than 125 state & local bomb and HAZMAT squads in the United States
- Security planners for Presidential Inaugurals and other high profile events
- More than 30 U.S. airports
- The U.S. Army, Navy, Marine Corps and Air Force

Fixed Bollards

The BLG-02, BLG-04 and BLG05 models can be supplied in a fixed static application without any alteration of crash performance or visual appearance. The fixed bollards are ideal for security planners working in power denied environments who do not need the bollards to retract.



- No electrical hook-up required
- Cost effective
- Zero on-site integration
- K4, K8, K12 crash ratings
- Optional LED lighting package



**NABCO:
A TRUSTED
PARTNER**

Security personnel in the U.S. and more than 20 countries around the world rely on NABCO.

Our long-term partnerships have enabled NABCO customers to improve safety and up-level readiness against constantly evolving threats.

OUR CUSTOMERS:

- The FBI, ATF, CIA, NSA, NIH, Secret Service and Capitol Police
- More than 125 state & local bomb and HAZMAT squads in the United States
- Security planners for Presidential Inaugurals and other high profile events
- More than 30 U.S. airports
- The U.S. Army, Navy, Marine Corps and Air Force



Shallow Mount Fixed and Removable Bollards

The BLG-02-SM-200 and BLG-02-SM-350 models can be supplied in a fixed static application without any alteration of crash performance or visual appearance. The fixed bollards are ideal for security planners working in power denied environments who do not need the bollards to retract. What sets these bollards apart from other crash rated fixed bollards is the engineered base which allows for placement with minimal excavation requirements.



- Fixed or removable
- No electrical hook-up required
- Cost effective
- Zero on-site integration
- K4 crash rating
- 200mm Diameter
- 350mm Diameter

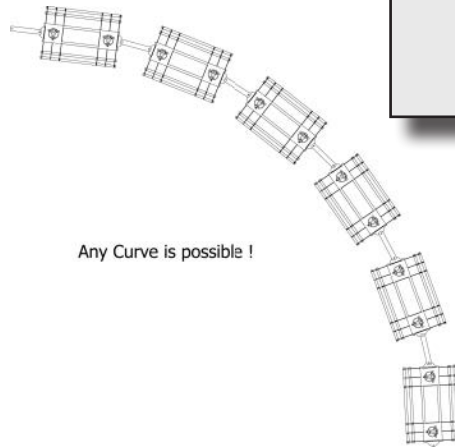
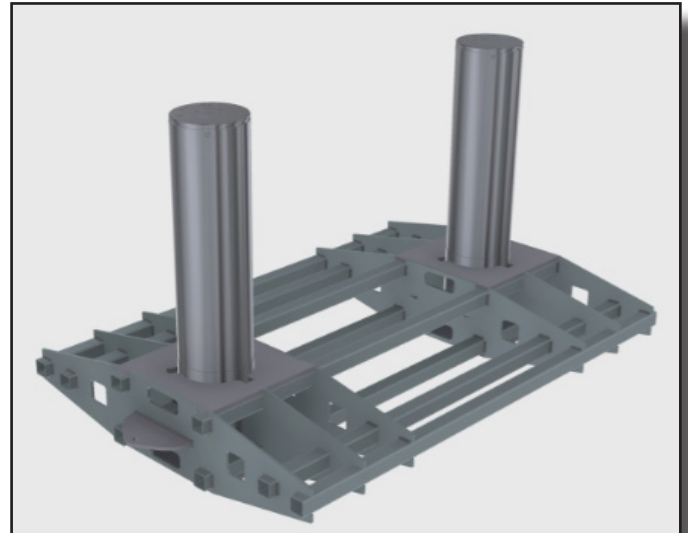

Any Curve is possible !

**NABCO:
A TRUSTED
PARTNER**

Security personnel in the U.S. and more than 20 countries around the world rely on NABCO.

Our long-term partnerships have enabled NABCO customers to improve safety and up-level readiness against constantly evolving threats.

OUR CUSTOMERS:

- The FBI, ATF, CIA, NSA, NIH, Secret Service and Capitol Police
- More than 125 state & local bomb and HAZMAT squads in the United States
- Security planners for Presidential Inaugurals and other high profile events
- More than 30 U.S. airports
- The U.S. Army, Navy, Marine Corps and Air Force

Surface Mounted Vehicle Damper

The vehicle damper system blocks unauthorized vehicles from entering controlled passages. The system is designed as an upper surface mount to be installed in permanent and temporary applications. The damper system is modular and can be extended to fit any entrance width and requires zero excavation.

- Surface mounted
- Cost effective
- Zero on-site integration
- C50 rating
- Modular portable system

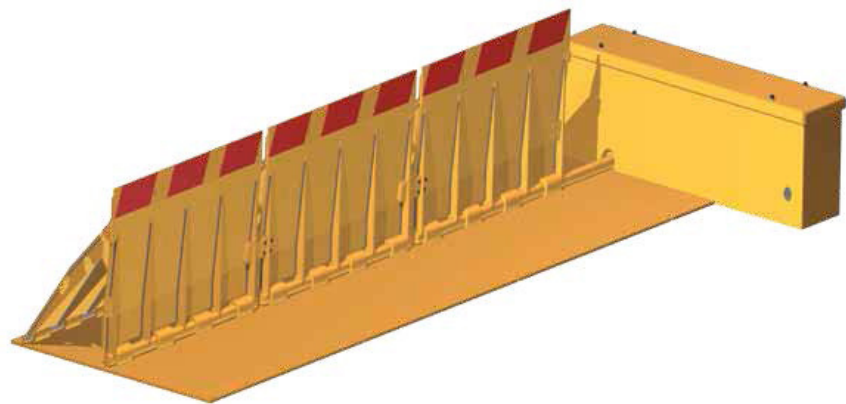

**NABCO:
A TRUSTED
PARTNER**

Security personnel in the U.S. and more than 20 countries around the world rely on NABCO.

Our long-term partnerships have enabled NABCO customers to improve safety and up-level readiness against constantly evolving threats.

OUR CUSTOMERS:

- The FBI, ATF, CIA, NSA, NIH, Secret Service and Capitol Police
- More than 125 state & local bomb and HAZMAT squads in the United States
- Security planners for Presidential Inaugurals and other high profile events
- More than 30 U.S. airports
- The U.S. Army, Navy, Marine Corps and Air Force



Active Vehicle Barriers

The Road Blocker series are shallow mounted, heavy duty systems that provide the ultimate protection against hostile vehicles. Equipped with a manual back-up system to operate in the event of power failure and emergency fast-operation for last minute deployment ensuring the maximum perimeter protection.



- Shallow mount
- Low maintenance
- Optional skirt
- ASTM K12/M50
- EFO



The barrier systems may be operated wirelessly from an off-site location allowing full command and control of all aspects of the perimeter.

10001 Franklin Square Drive • Nottingham MD USA 21236
410-933-0401 • FAX: 410-360-3255
Website: www.nabcosystems.com
Email: info@nabcosystems.com

**NABCO:
A TRUSTED
PARTNER**

Security personnel in the U.S. and more than 20 countries around the world rely on NABCO.

Our long-term partnerships have enabled NABCO customers to improve safety and up-level readiness against constantly evolving threats.

OUR CUSTOMERS:

- The FBI, ATF, CIA, NSA, NIH, Secret Service and Capitol Police
- More than 125 state & local bomb and HAZMAT squads in the United States
- Security planners for Presidential Inaugurals and other high profile events
- More than 30 U.S. airports
- The U.S. Army, Navy, Marine Corps and Air Force

Optimus A-260

Product	Optimus / A-260
Height above road	39" / 1000mm
Foundation depth	13.5" / 350mm (optional surface mount)
Operation speed	3 sec
Emergency fast operation	2 sec
Protection level	ASTM F2656 07-M50-P1 Zero Penetration Optimus continues working after crash.
IP rate	IP-68 can work completely submerged in water
Length	8.2ft, 9.8ft, 11.4ft, 13.1ft

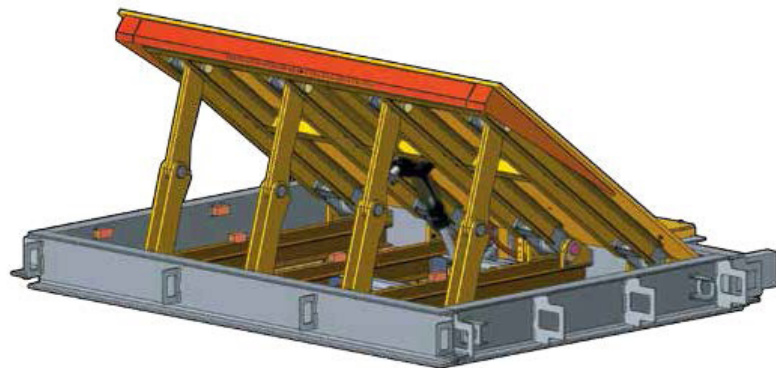

**NABCO:
A TRUSTED
PARTNER**

Security personnel in the U.S. and more than 20 countries around the world rely on NABCO.

Our long-term partnerships have enabled NABCO customers to improve safety and up-level readiness against constantly evolving threats.

OUR CUSTOMERS:

- The FBI, ATF, CIA, NSA, NIH, Secret Service and Capitol Police
- More than 125 state & local bomb and HAZMAT squads in the United States
- Security planners for Presidential Inaugurals and other high profile events
- More than 30 U.S. airports
- The U.S. Army, Navy, Marine Corps and Air Force



Arm Barriers

Security arm barriers come in a wide variety of pneumatic and electric arm systems. The arm barriers may be used as stand-alone systems or can be easily integrated to compliment our other products such as wedge barriers or bollards to create a more in-depth entrance system.

High Security Arm Barriers

	EL-08-1	EL-09-1
Operation	Manual/Electrical	Electro-Hydraulic
Arm Length	Up to 26ft	Up to 18ft
Speed	8 sec	6 sec
Protection	K4 rated	K8 rated



- K4/K8 Rated
- Low maintenance
- EFO
- Manual locking

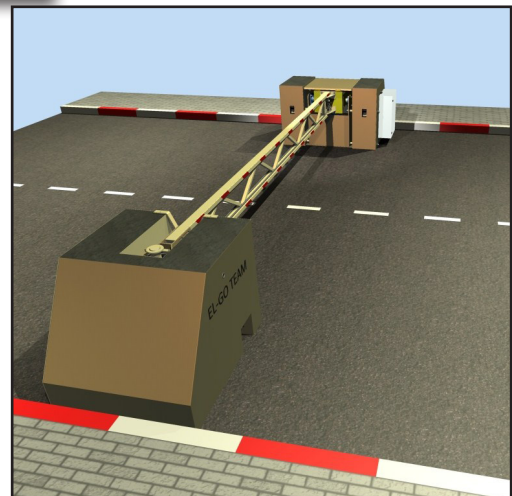

**NABCO:
A TRUSTED
PARTNER**

Security personnel in the U.S. and more than 20 countries around the world rely on NABCO.

Our long-term partnerships have enabled NABCO customers to improve safety and up-level readiness against constantly evolving threats.

OUR CUSTOMERS:

- The FBI, ATF, CIA, NSA, NIH, Secret Service and Capitol Police
- More than 125 state & local bomb and HAZMAT squads in the United States
- Security planners for Presidential Inaugurals and other high profile events
- More than 30 U.S. airports
- The U.S. Army, Navy, Marine Corps and Air Force



Additional Products

In our effort to provide a holistic security and perimeter security solution, we are able to offer a wide array of additional products that may be integrated into all of our solutions. Additional Products Include:

- Spike systems
- Turnstiles
- Concrete barriers
- Concrete planters
- Wheel locks
- Bollard trolleys
- Traffic lighting
- Remote receivers

Command and Control

Off-Site Security Operation

All automatic systems including bollards, barriers, drop arms and turnstiles may be operated wirelessly from an off-site location. This setup allows security personnel to operate systems and secure the perimeter from a command center. Or for public works personnel to secure roads and areas during maintenance or pedestrian access periods. The integrated system provides a secure connection to the systems allowing security monitoring and engagement around the clock even in an unmanned location.

**NABCO:
A TRUSTED
PARTNER**

Security personnel in the U.S. and more than 20 countries around the world rely on NABCO.

Our long-term partnerships have enabled NABCO customers to improve safety and up-level readiness against constantly evolving threats.

OUR CUSTOMERS:

- The FBI, ATF, CIA, NSA, NIH, Secret Service and Capitol Police
- More than 125 state & local bomb and HAZMAT squads in the United States
- Security planners for Presidential Inaugurals and other high profile events
- More than 30 U.S. airports
- The U.S. Army, Navy, Marine Corps and Air Force



Suspected Device Containment

For over 30 years NABCO has specialized in developing gold-standard solutions for explosive containment. We have options to suit any security and screening needs and an array of explosive containment ratings.

All of our products have been tested to their full rated capacity with live explosives.

Suspected Parcel Containment Vessel (SPCV)

Standard Features:

- Basic package tray
- Manual door
- Hand push or tow by vehicle
- Compatible with all EOD x-ray systems



- Contains up to 2lbs TNT
- Package length-32"
- Package width- 26"
- Package height- 15"
- Vessel length- 68"
- Vessel width-33"
- Vessel height-49"

The SPCV is designed to be integrated into existing conveyor systems and seamless integration into screening checkpoints. Sized to fit through a standard door, the SPCV is easily maneuvered through tight areas.

**NABCO:
A TRUSTED
PARTNER**

Security personnel in the U.S. and more than 20 countries around the world rely on NABCO.

Our long-term partnerships have enabled NABCO customers to improve safety and up-level readiness against constantly evolving threats.

OUR CUSTOMERS:

- The FBI, ATF, CIA, NSA, NIH, Secret Service and Capitol Police
- More than 125 state & local bomb and HAZMAT squads in the United States
- Security planners for Presidential Inaugurals and other high profile events
- More than 30 U.S. airports
- The U.S. Army, Navy, Marine Corps and Air Force

Suspected Luggage Containment Vessels (SLCV)

Our SLCV models come in three different sizes to accommodate varied needs within the security community. The larger size is geared to accommodate luggage and can be integrated into conveyor systems in airport baggage handling areas, or directly into a screening station.

Standard Features:

- Electronically-operated door
- Four wheeled cart
- Hand steering or tow by vehicle
- Compatible with all EOD x-ray systems

Options:

- Motorized cart
- Road-ready trailer mount
- One-touch programmable logic control operation
- Automated drawer
- Roller drawer
- Adjustable height



**NABCO:
A TRUSTED
PARTNER**

Security personnel in the U.S. and more than 20 countries around the world rely on NABCO.

Our long-term partnerships have enabled NABCO customers to improve safety and up-level readiness against constantly evolving threats.

OUR CUSTOMERS:

- The FBI, ATF, CIA, NSA, NIH, Secret Service and Capitol Police
- More than 125 state & local bomb and HAZMAT squads in the United States
- Security planners for Presidential Inaugurals and other high profile events
- More than 30 U.S. airports
- The U.S. Army, Navy, Marine Corps and Air Force

SLCV/SPCV Spec Sheet

Specification	Unit	SLCV-01	SLCV-02	SLCV-03	SPCV
Containment Capacity	pounds kg	5 TNT 2.3 TNT	5 TNT 2.3 TNT	7 TNT 3.2 TNT	2 TNT 1 TNT
Package Length	inches cm	44 112	44 112	44 112	32 81
Package Width	inches cm	15 38	24 61	20 51	26 66
Package Height	inches cm	26 66	26 66	26 66	15 38
Total Length	inches cm	89 226	91 231	91 231	68 173
Total Height w/ Door Open	inches cm	113 287	107 272	107 272	64.5 164
Total Width	inches cm	51 130	65 165	61 155	33 84



**NABCO:
A TRUSTED
PARTNER**

Security personnel in the U.S. and more than 20 countries around the world rely on NABCO.

Our long-term partnerships have enabled NABCO customers to improve safety and up-level readiness against constantly evolving threats.

OUR CUSTOMERS:

- The FBI, ATF, CIA, NSA, NIH, Secret Service and Capitol Police
- More than 125 state & local bomb and HAZMAT squads in the United States
- Security planners for Presidential Inaugurals and other high profile events
- More than 30 U.S. airports
- The U.S. Army, Navy, Marine Corps and Air Force

Blast Resistant Trash Receptacles

Blast resistant trash cans have become an important prevention tool in the fight against terrorism. Traditional trash receptacles provide perpetrators an easy place to conceal explosive devices and create maximum damage to innocent bystanders.

Blast Resistant Trash Receptacles provide 360° lateral protection from blast pressure and fragmentation and are ideal for use in high-profile settings such as transit stations, airports, stadiums, courthouses, public parks, and anywhere else large crowds form.

BCRs are also deployed by law enforcement and security personnel at special events to quickly store any suspect packages that are discovered. Utilizing this blast mitigating technology while evacuating nearby areas further decreases risk to both the officers and the general public.

All of our products have been tested to their full rated capacity with live explosives.



Model	Internal Volume	Can Dimensions	Weight
BCR X10	10 gallons	21 inches x 29 inches	225 pounds
BCR X20	20 gallons	25 inches x 35 inches	315 pounds
BCR L1	40 gallons	29 inches x 39 inches	790 pounds
BCR L3	40 gallons	30 inches x 39 inches	1100 pounds

10001 Franklin Square Drive • Nottingham MD USA 21236
410-933-0401 • FAX: 410-360-3255
Website: www.nabcosystems.com
Email: info@nabcosystems.com



**NABCO:
A TRUSTED
PARTNER**

Security personnel in the U.S. and more than 20 countries around the world rely on NABCO.

Our long-term partnerships have enabled NABCO customers to improve safety and up-level readiness against constantly evolving threats.

OUR CUSTOMERS:

- The FBI, ATF, CIA, NSA, NIH, Secret Service and Capitol Police
- More than 125 state & local bomb and HAZMAT squads in the United States
- Security planners for Presidential Inaugurals and other high profile events
- More than 30 U.S. airports
- The U.S. Army, Navy, Marine Corps and Air Force



Explosive Detection

EXPRAY® and DROPEX

The EXPRAY® and DROPEX technology covers most commercial and improvised explosives using easy to use aerosols and bottled liquids.

- Quick test results
- Sensitivity to nanogram amounts
- Temperature tolerance from 0-125 degrees F
- Packages from 50 to 100 test sizes



Applications

- Screening checkpoints
- Critical infrastructure
- Abandoned facilities
- Laboratories





NABCO Public Safety Solutions

NABCO: A TRUSTED PARTNER

Security personnel in the U.S. and more than 20 countries around the world rely on NABCO.

Our long-term partnerships have enabled NABCO customers to improve safety and up-level readiness against constantly evolving threats.

OUR CUSTOMERS:

- The FBI, ATF, CIA, NSA, NIH, Secret Service and Capitol Police
- More than 125 state & local bomb and HAZMAT squads in the United States
- Security planners for Presidential Inaugurals and other high profile events
- More than 30 U.S. airports
- The U.S. Army, Navy, Marine Corps and Air Force



Contact Us

info@nabcosystems.com
www.nabcosystems.com
+1 (410) 933-0401



10001 Franklin Square Drive • Nottingham MD USA 21236
410-933-0401 • FAX: 410-360-3255
Website: www.nabcosystems.com
Email: info@nabcosystems.com